



Seekonk Sport Trucks 2022

Official Rules 5/17/202 R2

1.0 General Specifications

NOTICE: When used in the rules, the term "stock" or OEM includes after-market products and components that must conform to original equipment manufacturer specifications. There is No alterations to components or specifications unless specifically provided for in the rules.

1.1 PICKUP (COMPACT) TRUCKS: manufactured from 1982 to 2002 with a maximum wheelbase of 108".

4WD or any type extended cabs or long beds are not permitted. Eligible chassis: Ford Ranger - Chevy S10 - GMC Sonoma - Nissan Hard body - Toyota Tacoma

Option: Metric Chassis see rule: 4.7

1.2 ROLL CAGE: Roll cage must have a four-point symmetrical structure fully extending from left to right connecting off the chassis side rails using minimum 1¾" O.D. seamless steel tubing with a .090" wall thickness. Side rails must be 2" wide by 3" high steel box tubing of equal length with a .120" wall thickness and must connect from front to back forming an outside frame rail. Kick-out connectors used to support off stock chassis must be of equal length on each side, no less than .083" wall thickness. No holes are permitted to side frame rails, connectors, or any part of the original truck's frame within the roll cage area. Roll cage may not be offset from frame. Width of top halo bar (above driver's head) cannot be offset. Halo must follow roof outline and have a minimum of one (1) full cross bar. Minimum of three (3) (full-length) door bars in right side door area required, bars may be .065" wall thickness. Four (4) horizontal door bars required on driver's side with a minimum of two (2) vertical bars connecting each horizontal bar, for a minimum of six (6). The top horizontal door bar on each side of the roll cage must have a minimum height of 22½" from bottom of chassis to top of bar. **The placement of driver's side intrusion plates is mandatory. Solid steel plates of 0.125" (1/8") either inside, outside or between horizontal door bars. Door plates must be bolted or welded in place.** Vertical vent window bars must be welded from top of the door bars to the side of front roll bar legs. Roll bars may extend to front of chassis. Roll bars connect to top of rear hoop down to chassis, minimum 1¾" tubing. **NO OTHER BARS MAY SHOW ABOVE TOP OF BED.**

1.3 SEAT: Must be bolted to a sub-frame attached to the roll cage. Seekonk recommends that all seats be full containment type constructed of aluminum. Design shall include comprehensive head surround, shoulder and torso support system, energy impact foam, and removable head foam. Seats must be securely fastened per manufacture guidelines. Seat must be located to the inside of main frame rail fabricated for roll cage and no lower than 4" measured from the bottom of the stock chassis.

The stock frame may be notched only to lower driver's seat. All roll bars within driver's reach must be padded.

1.4 SEAT BELTS: It is recommended that the seat belts used are 5-point harness securely fastened to the roll cage or chassis per manufacture guidelines. 6-point harness is highly recommended. Belts must be no less than 3" wide. When a HANS restraint device is used a 2" wide shoulder harness may be used if required. A quick-release mechanism must be fastened to lap belt. Y-type shoulder harness prohibited. Where the harness crosses the roll cage, it should pass through a steel guide welded to the roll cage that will prevent the harness from sliding side to side. Manufacturer's date must not exceed three (3) years. Belts with no date or belts that show signs of wear will not be eligible for use.

Head & neck restraints are highly recommended.

Competitors must use a SNELL SA2010 or higher FULL-FACE helmet. Only "SA" Special application helmets permitted, NOT "M" (motorcycle). All drivers must wear S.F.I. approved fire-resistant SUITS, SHOES and GLOVES. Suits must be in good condition and free of holes, rips, grease, oil, etc. If your suit or shoes are deemed unsafe, you will not be allowed to compete. The car owner and driver are solely responsible for the installation of seat belts and seats in accordance with the manufacturer's specifications.

1.6 BATTERY & QUICK-DISCONNECT SWITCH: Battery relocation must be behind driver, inside chassis rails. No positive battery cables may be located on outside of roll cage. Switch must be located near center of dash, accessible to driver or safety crew. Switch must be clearly marked On/Off (This switch must totally disconnect the battery from the system)

2.0 Mechanical Rules

GM P/N 88958602/19258602 350 crate engine may be used. All rules listed for V8 engines will apply to the 602 crate engine unless noted. Crate engine option allows any body manufacture to be used.

Crate engine option

All crate engines must be sealed by an authorized engine builder that's part of the RPM Seal Alliance program before they are eligible for use. The base engine (P/N 88958602/19258602) is listed in GM's parts catalog with a service parts list. No parts can be altered or replaced with any other manufacturer, or another GM part number, that does not belong to the engines parts list. Valve covers may not be replaced.

The seals from the RPM Alliance may not be removed or tampered with in any way. We are committed to this program and the future of its success. If the Speedway discovers that any competitor tampers with their crate engine, the Speedway will impose strict penalties as outlined in section 12.0 of the General rules.

RPM Seal Alliance information. Seekonk Speedway has partnered with RPM Racing Engines in Georgia, Vermont. For more information regarding the RPM Engine Seal Alliance Program, competitors may contact RPM Engines at 802-524-7406 or any of the approved engine builders.

The following are current approved Engine Builders in the RPM seal program:

- RPM Racing Engines -- Vermont
- Nat's Racing Engines – Massachusetts (508-336-4142)
- Larry's Auto Machine – Connecticut
- Redline Performance – Maine
- R.A.D. Auto Machine – Massachusetts
- S&S Performance – Maine
- Mac Pro Shop – Quebec, Canada
- Thayer's Automotive -- Maine

2.2 ENGINES: Only three production cast iron engines are eligible as listed: Chevy 305, Ford 302, and Dodge 318. All engines must retain stock factory bore and stroke. No custom strokes permitted. A maximum overbore of .040" permitted. Engines may only use stock OEM parts as replacements. No special production parts permitted. No ceramics or paint coatings allowed on any internal parts.

2.3 CRANKSHAFT: Only stock permitted. No lightening permitted. Stroke must be maintained within +/- .015", only stock or stock replacement engine dampeners permitted.

2.4 CONNECTING RODS: Only stock unaltered cast or forged steel connecting rods permitted. Journal size and rod length stock specifications.

Ford - 5.09", Chevy - 5.7", Dodge - 6.123". No machine work.

2.5 PISTONS: Only stock cast or Hypereutectic, dished or flat tops for the particular engine used. An-aftermarket may be used that is identical to stock in weight and appearance. No custom or light weight pistons allowed. No gas porting on piston rings. Wrist pins must be pressed-in type. Any stock type piston ring permitted. No "Dykes", Head-land or gapless designs. Maximum compression 9.5:1 checked with Whistler.

2.6 CYLINDER HEADS: Only cast iron stock production permitted. GM must use 305 castings, Ford must use 302 castings and Dodge must use 318 castings. The heads listed are NOT eligible: bow tie, angle plug, canted valve, marine-type, Chevy vortec, ~~Ford GT-40~~, Boss 302, Dodge magnum type or any special, high performance. No porting, polishing or grinding permitted. Heads must be in their original, as-cast condition. Maximum static compression 9.5:1 checked with whistler device.

Maximum Stock valve sizes:

GM -1.86"/1.50" & Ford - 1.78"/1.46" & Dodge - 1.78"/1.50"

GM STOCK 305 cylinder head numbers permitted:

10065205, 10065207, 10159551, 10159553, 12509859, 14010201, 14014416, 14019926, 14020555, 14022301, 14022801, 14039121, 14039122, 14101081, 14102187, 14102191

Option: These aftermarket cylinder heads maybe used. No changes from stock form permitted.

Chevy - Dart SS, Engine Quest #CH350I, WP SR Torquer. Valve size 1.94"/1.50"

Ford – Dart Iron Eagle 180cc, WP Windsor Jr. Valve size 1.95"/1.60"

Only steel valves permitted, No light weight. Three angle valve cuts permitted. When cutting the valve seat angles, no stone or grinding marks are permitted above the bottom of the valve guide. All cutting in reference to the valve job must be centered off the centerline of the valve guide. Upon completion of the valve job, the bowl area under the valve seat down to the bottom of the valve guide should still be the same configuration as far as shape and finish as it was stock. Surfaces and/or edges where the cutter or stone has touched may not be polished. Only stock diameter single valve springs permitted. Retainers and keepers must be stock, steel. Rocker studs may be replaced with screw-in studs.

All heads must have visible and unaltered casting numbers. Any cylinder heads with unreadable or altered casting numbers will not be allowed.

Valve covers may be steel or cast aluminum only. No Evac breather systems.

2.7 VALVE TRAIN: After-market camshafts allowed, only hydraulic cams and lifters permitted. Camshaft lift cannot exceed gross valve lift divided by stock rocker arm ratio. Maximum Cam lift allowed is listed below to engine manufacture. Stud girdles, offset rocker arms, roller rockers or roller pivot rocker arms NOT permitted. Any steel, timing chain permitted.

Rocker arms and push rods must remain stock OEM to engine make, Rocker arm ratio Chevy & Dodge 1.5 / Ford 1.6 Factory guide plates and lifter valley baffles permitted.

Valve lift: Chevy & Dodge .450 / Ford .480

2.8 INTAKE MANIFOLD: The only eligible intakes permitted are from Edelbrock "Performer series". Manifolds must remain as manufactured.

P/N Chevy 2104 or 2101 - Ford 2121 - Dodge 2176

2.9 CARBURETOR: Crate engine must use Holley #7448 or #80787. All other engines may use Holley #4412 or #80583 or 441BKX. Induction hats, baffles, ducts or dividers "NOT" permitted on or leading to the air cleaner or element. Top of air cleaner must be completely steel or aluminum. No cowl air inductions. Modifications to increase or change airflow "NOT" permitted. Carburetor is subject to inspection with no-go gauges. Only one (1) spacer plate permitted 1" inch maximum height with standard gaskets. Internal walls of spacer must be parallel to each other with no beveling, tapering, or flaring. No angled holes.

Approved fiberglass body option with correct tags (Haltin Customs) may use cowl induction as supplied with the body package. No changes permitted.

2.10 FUEL SYSTEM: Fuel shut off mandatory. Mechanical pumps must use fuel line safety valve OBERG SV-0828 or SRI Performance FPF-FSV installed at top of cell.

Electric pump permitted must be wired to shut down by battery disconnect switch and oil pressure switch.

2.11 IGNITION SYSTEM: Stock OEM systems allowed. An after-market GM HEI distributor permitted for all engines keeping HEI cap, rotor and module (GM stamped) and may have mechanical or vacuum advances used. No dial adjustments. Crate engine must use GM P/N 93440806 supplied with engine with no modifications. Advance spring types open.

2.12 REV-CONTROL: Mandatory on all V8 engines. MSD P/N 8728 Soft Touch Rev Control, this RPM limiter must use 5300-RPM chip. Mandatory wiring connections from RPM module:

VIOLET- Must be cut back flush to RPM module. (Not used)

GREEN / WHITE - Connect directly to (-) negative side of coil, on HEI systems with coil in cap splice to BROWN wire from coil.

RED - to (+) side of coil, on HEI systems splice to PINK wire from coil.

BLACK – Connect to chassis ground.

MSD Placement: On top of dash on far-right side outside of drives reach. Wiring must run directly from RPM module to listed connections, these connections must be taped, or wire tied to prevent disconnection. All wiring must travel above dash in plain view if in wire loom this must be clear for track officials to perform inspections and testing. RPM limiter must be always operational. A mounting plate will be used under module that will

incorporate a locking bracket to limit access to RPM chip these mounting plates **MUST BE PURCHASED** from the track supplier; (*HALTON CUSTOMS*)

No cluster type digital dashes allowed. NO acquisition/computer data allowed of any kind.

2.13 OIL PAN: After-market, steel oil pans are permitted. Wet sump systems only.

2.14 BELT PULLEYS: After-market permitted steel or aluminum, belt type open.

2.15 WATER PUMP: Aluminum water pumps permitted. No Racemates - water pump/alternator.

2.16 EXHAUST: Headers permitted per guidelines. Stainless steel or Tri-Y not permitted. Headers must be commercially manufactured using steel primary tubes of 1 5/8" outside diameter and collector maximum 3". No step, reversion, anti-reversion, venturi multi or 180-degree types. No devices inside exhausts permitted to enhance performance.

Heat coatings & equalizer tubes and 2 into 1 connector is permitted. Exhaust must extend past driver no further then rear end underneath body and dump towards ground.

Mufflers mandatory, No inserts permitted. Sound level must not exceed 96 dB at 50ft. Strictly Enforced!

2.17 ENGINE POSITION: All engines; forward most spark plug hole must be even or ahead of an imaginary center line between upper ball joints. Crankshaft height 13" minimum.

3.0 Drive Train

3.1 REAR END: Only solid steel axles, No crown splines. Any stock or aftermarket steel rear end housing that is OEM in appearance permitted. Floater types allowed. Only steel hubs/drive plates. No cambered rear ends. Aluminum spools permitted. No limited slip or ratcheting differentials. Only cast Iron carriers permitted.

3.2 GEAR RULE: All trucks must run in a final drive, with transmission that is 1-to-1. Rear-end gear ratio must be **4.56**, NO other ratio permitted.

3.3 TRANSMISSION: No automatics. Only stock 3 or 4 speeds, No 5-speeds permitted. All gears must be in working order. No internal modifications from stock only standard bearings and gear ratios that are stock to production. Hydraulic clutch controls permitted. Any type shifter allowed. Full steel bell housings mandatory, No cast steel. Steel driveshaft only using steel yokes. Two (2) 360 degree 2" x 1/4" minimum steel driveshaft hoops mandatory.

3.4 FLYWHEEL & CLUTCH: Only stock clutches or direct replacements may be used. All components must be magnetic steel. Minimum clutch size is 10.4". No modifications. Minimum weight requirements: Flywheel 16 lbs., Pressure plate w/cover & clutch disc 20 lbs., clutch disc must be steel. Crate engine must use flywheel P/N 14088646 or 14088647, Minimum weight 15 lbs.

3.5 CLUTCH & BRAKE PEDALS: After-market clutch and brake pedals permitted. Brake proportioning valve that adjusts front to rear pressures permitted. No individual adjusters per wheel.

4.0 Suspension

4.1 SUSPENSION: Must match make of chassis. Jacking bolts permitted. Front and rear shocks may be relocated one (1) shock per wheel. No coil overs or coil over eliminators. Only leaf spring rear suspension permitted with older stock chassis, spring mounts may be relocated and altered, no other springs are allowed in combination with leaf springs. No pan hard bars permitted with leaf springs. Older ford I-beam front suspensions may be interchanged with 1974-1989 Mustang II front suspension, cross member between the stock chassis maybe no lower than 3". Only OEM steering boxes or OEM rack & pinion setups permitted. OEM steering racks must connect directly to spindle, no slide bars. Steel heim joints permitted to spindle. Any stock center link permitted. Steering arm and idler arm maybe changed.

4.2 *SUSPENSION COMPONENTS: Upper control arms (UCA) mounts may be relocated. UCA's may be changed to a standard steel replacement with aluminum cross shaft, No adjustable arms or heim joints. Lower control arms (LCA) must be stamped steel design and fit to chassis using stock mounting locations. Original mounting holes maybe lengthened with in stock brackets. Lower ball joints may be changed. **Steel after-market**

LCA's may be used. No heims or adjustable arms on LCA's. Spindles may be OEM or aftermarket cast iron, 3-piece GM metric spindles permitted (No light weight). Caliper placement behind ball joint. Spindle savers permitted.

Only conventional type steel coil springs permitted that maintain a consistent spacing and width between and across coils. Only one (1) spring rubber insert not to exceed full coil allowed per spring. Any wrapping or binding of the coils will not be permitted. All upward and downward chassis movement must be limited by the spring's rate or the bottoming of the chassis against the race track. Any compression or rebound limiting device or procedure is not permitted. Track Officials will check for travel limiting devices as follows: The front wheels will be positioned 1½" above the ground level and each truck's valence (air dam) or front cross member must travel downward beyond the 1½" touching ground when three (3) crewmembers push down on it, driver will remain in truck.

***TREADWIDTH.** All trucks will have a common tread width. Wheel spacers permitted, Maximum ½". Only one (1) spacer per wheel that must match left to right.

Maximum tread width 68", Measurement taken from outside lip of wheels at spindle height. ¼" tolerance.

4.3 SHOCKS: No adjustable or rebuildable. Steel only (sealed body) shocks using fixed bearing ends from list permitted. All shocks must have visible P/N label. Shocks may be relocated. Only one (1) per wheel. No bump stops, meaning nothing may be positioned on the shock shaft except travel indicator. Shocks must collapse all the way down making contact between body and lower jam nut at rod end. Shock shaft must be straight to body. Eligible shocks: Pro Shock - WB series: AFCO - 10 & 14 series: Integra - 421 series. No changing or altering shocks in any way from OEM specifications.

4.4 STEERING: One-piece steering shafts not permitted. Minimum two (2) u-joints are mandatory on steering shaft unless collapsible shaft is used. OEM rubber steering joint not permitted. Steering "Ratio multiplier" permitted. Quick release coupling MANDATORY. Center top of steering wheel must be padded.

4.5 BRAKES: Only OEM steel single piston calipers. Only standard OEM rotors or aftermarket minimum 10½" x .810" No drilling or lighting. Steel hats only. No brake fans. Only front to rear portioning valves in cockpit permitted.

4.6 RIDE HEIGHT: No lower than 4" for frame body and ballast, with driver in seat in full racing gear.

4.7 CHASSIS: Stock chassis must remain to manufactures specifications. Rear of chassis may be cut no further back then front of rear axle. Tubing may be used inside the stock chassis for support but may not be used to build an inner chassis that connects to outside fabricated side rails. Front section of chassis may be fabricated from cross-member forward following close to original design. Minimum 2" x 3" steel box tubing .083" must be used for both sections. Minimum wheelbase for any chassis is 102" - absolute / maximum 108".

GM-Metric option: The GM metric chassis is permitted per the specifications outlined to its construction. The introduction of this chassis is to offer a simple cost affective option to build a sports truck and is not intended to phase out any current chassis in use. These rules are only for the build and construction of this chassis and are not intended to be adapted to any other chassis. Only specific rules to this chassis and suspension will be listed here all other rules applied to this division are still to be used as part of the construction.

GM-metric option is a stock 1978-1988 GM metric chassis using the front snout and frame rails only.

1. Stock OEM frame rails may be replaced with 2" x 4" or 3" x 4" box tubing .120" wall thickness. Cut must be made at seam to stock snout, length measurement refer to (B) in diagram. Snout and frame rails must meet flush at connections. No off set permitted. OEM snout cross member may be notched for engine clearance. Center section may not be removed or sectioned. Chassis maybe notched for easy spring clearance. Jacking bolts permitted using minimum 5" springs. From spring buckets forward can be replaced 2"x 4" box tubing.

1-A. Stock OEM snout may be replaced with Johnson chassis (mandrel) #JCI-09-01-011 or Hamm's welding #GHC-54108 (mandrel/mitered) using 2" x 4" or 3" x 4" kickouts. Check diagram for placement.

1-B. Lower control arms (LCA) may remain stock or use fabricated LCA from Johnson or Hamm's welding as produced (must be of same length). LCA mounts can have slotted holes with in 3/8" from stock. All snouts must pass inspections checking LCA and steering alignment.

1-C. Upper control arm mounts must be a fixed vertical plate attached to top of chassis with adjustable holes. No slide adjusters. Aluminum shims permitted.

2. Steering: Only stock type steering boxes, arm lengths maybe changed. Idler arm maybe adjustable or have adjustment at mount. Stock center link must be used or listed aftermarket part numbers ONLY, Allstar P/N: ALL56330 or Keyser P/N:100-19902. Stock Inner tie rod ends with tapered shafts must be used. Aftermarket adjusting shelves and steel heim joints at spindles permitted.

3. Sway bar. One piece steel only. Maximum size 1½" inches. Adjustable front mounts permitted.

4. Coil springs: Front minimum - 5.0". Rear minimum - 2.5". Rear springs must be straight up and centered on top of rear axle and be INSIDE not below inner wall of chassis.

5. Both rear shocks must be positioned inside the chassis rails and behind rear end.

6. Panhard bar must be positioned with only two (2) connections behind rear end.

7. Rear suspension must use a 3-link setup only. All support arms (trailing arms) must be straight assemblies with no springs, rubbers, or similar attachments. Trailing arms & upper arm may be aluminum using steel heim or clevis joints. Trailing arms must be located inside the chassis rails and their connections must not be past location marked in (10) of diagram. Upper link connections must be above rear end and may not travel past line (10A) in diagram and be no further than 6.5" from driveline (10B) in diagram. Brackets connecting to lower arms to rear end must be STEEL and no lower than 4" from bottom of axle tube to location of were arm pivots. No floating brackets.

Metric chassis diagram chart identification. If a tolerance is given it will be listed with rule.

A- Centerline hole, Forward placement of snout will use two holes for measurements. OEM - 26.5". Johnson/Hamm - 27.125". +/- ½". Snout MUST be centered to frame rails.

B- Frame rail lengths, from snout centerline hole to end of rail - 75" Maximum.

C- Chassis frame rails width outside to outside 54.0". +/- ½". No offset from centerline.

D- Rear clip outside to outside 42.0". Mounted centered to frame rails.

E- Wheelbase length 102.0" minimum. No tolerance.

F- Rear clip length 66.0". +/- ½".

G- Roll cage length, measured outside of main posts - 44.5". +/- ½".

H- Roll cage height; top of cage to bottom of chassis - 47.0". +/- ½". Cage must stand at 90 degrees to chassis and not go further back than frame rails allow at 74.5". Refer to (B)

I- Roll cage halo 44.0" length / 29.5" width. +/- 1.0".

J- Down bars from main cage - top 38.0" outside to outside +/- 1.0". Bottom attach to end of chassis piece (N). Bars may intersect with other bars before connection to chassis.

K- Roll cage A-post leg and foot bar maybe moved 3.0" to outside of main frame rail. 2" x 4" tubing .120" wall, must be used under the repositioned bars welded off main frame rail or in front of kickout. This is the only portion of cage allowed to be repositioned giving more leg room to driver.

Rear clip consists of 5-pieces L thru P using 2" x 3" .083" steel box tubing. All angles are with 36 degree cuts. Listed are the lengths of each piece before angle cuts are made. Don't forget to factor in blade widths of saw when measuring.

L- 18"

M- 18"

N- 19"

O- 10"

P- 25"

Q- Length between L to O rear clip 41"

4.8 *WEIGHT: Truck weight will be determined with driver in seat race-ready at track scale. **GM-Metric option trucks – 2850lbs All other trucks 2800lbs. All maximum left side 56%.**

No fluids or dislodged weight may be added after race. Only lead permitted as ballast no tungsten or other exotic metals. Any ballast mounted behind rear wheels may only be 3" away from side frame rails to outside; not to extend past fuel cell. **All ballast must be in block form no less then 5lbs and securely bolted in two places Min- 7/16" shaft bolts. Bolts must not spread longer than 8" apart or more bolts must be added.** No weight

shifting devices. NOTE: All ballast must be painted white with truck number on it.

5.0 Body

5.1 BODY: Bodies must follow measurements outlined in chart keeping to stock appearance.

ALL trucks must have wheels (tire bulge) under body panels. Ford, Chevy or Dodge must use the same make front nose cover that matches the body to the motor. Stock OEM cabs must be original sheet metal using stock top door frame to keep original outline, the remainder of the body may be fabricated with aluminum or steel panels. All hoods must be flat with no step ups or hood scoops. Truck bed may connect directly to back of cab. The cab interior floor, foot box area, drive shaft tunnel and front and rear firewalls must be fabricated using **steel only** MIN - .031". Interior sheet metal extending upward from OUTSIDE of driveshaft tunnel to the top of the right side door and dash above front firewall may be .040" aluminum, full enclosures not permitted. Front windshield must be clear Lexan, 1/8" minimum and use one center support. Vent windows may not extend past top of windshield.

Driver's last name must be placed across top of windshield with car number to the right.

No exterior/interior scavenging/aero panels allowed on body, including behind cab on roll bars (except Haltin bodies). Rear window must be clear Lexan, no stickers permitted. Body and engine must match except with crate engine option.

Body Option: Haltin Customs is the only eligible complete fiberglass body permitted. The Haltin body must be used in its complete form with all tag indentifications in place with decal package to be eligible using 8" spoiler and cowl induction. **The body angles and shape as produced by Haltin Customs cannot be altered.**

Spoiler & cowl induction maybe be removed or even weight adjusted if body is not approved by Tech Officials.

Rear cab measurement (chart "O") If found to be over 75" but no more than 76", wheelbase must be 103" minimum. Haltin body parts can be interchanged with metal body conforming to metal body rules.

Heights: All heights will be measured with driver at track scale pad race ready.

NASCAR / Seekonk contingency sponsor decals are required on each truck per the guidelines of the decal package at the start of the season. Decals must be placed between the fender and the door identifying the series sponsor and contingency sponsors. Failure to display sponsors could reduce point fund awards.

Sport Trucks transponder must be mounted 78" back measured from center of front wheel to center of transponder on left side. There must be no obstruction below the transponder to the ground.

SEEKONK SPORTS TRUCK BODY DIAGRAM

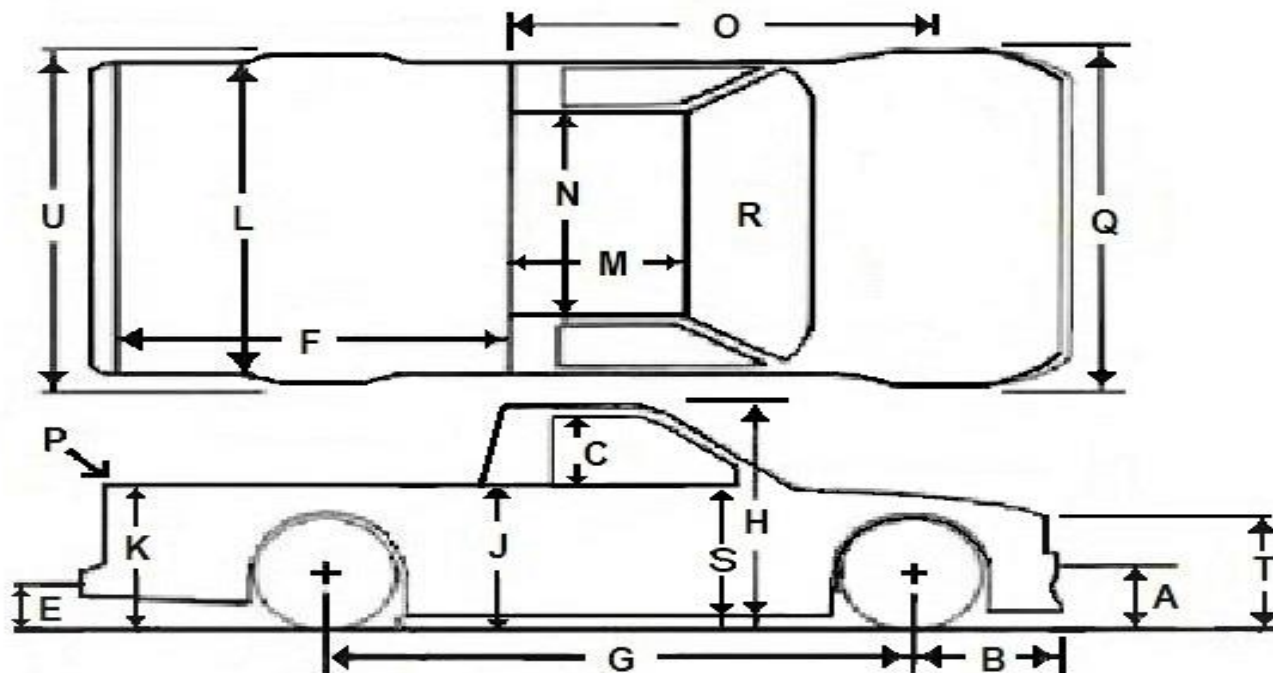

	METAL BODY			FIBERGLASS BODY		GEN 1	GEN II
A	Front bumper height (Center)	14"	A	Front bumper height (Center)	14"	14"	
B	*Front Overhang	36" Max	B	*Front Overhang	36" Max	TBD	
C	*Side Window Opening	15.5" Min	C	*Side Window Opening	15.5" Min	TBD	
D	Body Height	4" Min	D	Body Height	4" Min	4" Min	
E	Rear Bumper Height (Center)	14"	E	Rear Bumper Height (Center)	14"	14"	
F	Top Bed Length	72" Max	F	Top Bed Length	72" Max	72" Max	
G	Wheelbase Min-Max	102" 108"	G	Wheelbase Min-Max	102" - 108"		
H	Roof Height (Center)	52" Min	H	Roof Height (Center)	53" Min	53" Min	
J	Door Height - 1" difference from K		J	Door Height - 1" difference from K		36" Max	
K	Rear Quarter Height - 1" difference from J		K	Rear Quarter Height - 1" difference from J		38" Max	
L	Top Bed Width	63" Max	L	Top Bed Width	63" Max	TBD	
M	Roof Length	Stock	M	Roof Length	33"	TBD	
N	Roof Width	Stock	N	Roof Width	51"	TBD	
O	Rear of B Post to Spindle	74" Max	O	Rear of B Post to Spindle	74" Max	75" Max	
P	Spoiler H x W	5" x 63"	P	Spoiler H x W (Clear)	8" x 63"	8" x 63"	
Q	Body Width (Front) Must cover tires 74"	Max -	Q	Body Width (Front) Must cover tires Max - 74"		74" Max	
R	Windshield Angle (Center)	38 deg Min	R	Windshield Angle (Center)	38 deg Min	TBD	
S	Top of Door (where fender meets)		S	Top of door (where fender meets)		34 ¾"	
T	*Top of Nose to Ground	27" Min	T	*Top of Nose to Ground	27" Min	TBD	
U	Body Width (Rear) must cover tires		U	Body Width (Rear) must cover tires		TBD	

TBD on GEN II body is in place to follow with a template rule that is being worked on. When body is mounted to listed dimensions all TBD measurements will pass if no alterations are made to body. It is Highly recommended to call Haltin customs and follow mounting instructions profited.

5.2 BED: Top of bed must be fully covered with any door openings hinged towards cab. **Aluminum** panels may be used .040" minimum. Rear tail gate must be flat being 90 degrees to ground.

5.3 SPOILER: Rear spoiler, Maximum 63" wide, See height rule in body chart. All brackets must be at rear of spoiler, maximum ½" dimensions. Spoiler must be clear lexan with no decals.

5.4 BUMPERS: Only stock-type bumpers may be exposed and wrap into body, no less than 4" wide. Tube, I-beam or other fabricated bumpers must be covered under body panels and CAN NOT be exposed. **Bumper height is 14" from center to ground.**

5.5 RUB RAILS: If used, must be carbonate type as manufactured by Five Star bodies or similar. No solid types; must be mounted directly to body. Only (1) per side. Jack post must not protrude from body.

5.7 DRIVER'S WINDOW NET: Mandatory, ribbon or mesh type securely hinged from bottom, with quick release buckle or lever-type latch at top.

5.8 NUMBERS: All trucks must have assigned numbers on both sides of body also roof, right taillight, and top right of windshield. Roof numbers must face passenger side of truck. Numbers must be a minimum height of 18" and 3" in width. Only flat paint is to be used on windshield and tail light numbers - size minimum 3".

6.0 Gasoline and Fuel Cell

6.1 FUEL: Only automotive gasoline may be used. Gas shall not be blended with alcohol, ethers, or other

oxygenates and shall not be blended with aniline or its derivatives, or nitrogen containing compounds. All fuel will be randomly tested. Defined automotive gasoline by speedway;

The only approved fuels are unleaded automotive pump 87, 89 or 93 octane fuels sold from a retail outlet containing a minimum of 7% to a maximum of 10% ethanol. Fuel must remain as sold from retail outlet. If race fuel is used only track supplied fuel may be used. No mixing of Automotive and Race fuel
Approved Fuel: TBA and will be supplied at Track.

6.2 MANDATORY FUEL CELL: (Maximum 8-gallon) must be fully enclosed by steel. Bed must be completely sealed to protect the driver. Check valve required of vent line. Cell must be securely bolted to support braces connected off chassis with at least three (3) 1" x 1/8" steel straps under fuel cell and two above so as not to have any movement. Fuel cell must be centered in rear of truck (behind rear end). Minimum 6" inches from ground at lowest point. A crash bar must be placed at rear of truck to protect fuel cell, 1 3/4" tubing.

7.0 Tire and Wheel Rules

7.1 WHEELS: Steel 14" X 7". Mandatory wheel rule in effect. Older Diamond double center and Independent wheels previously used will still be eligible for use.

Bassett wheel is the manufacturer, and they will be supplied by North East Racecars NERACE.

Harrisville, RI. Contact info: 800-766-4748 or 401-710-992. These rims are of a specific backspace and must be from this supplier to be eligible for use. No pressure relief valves allowed. Steel studs 5/8" required.

7.2 TIRES: NO TIRE SOFTENERS OR TREATMENTS OF ANY KIND ALLOWED. Tires will be subject to but not limited to durometer testing at any time. **Tires MUST be purchased from Seekonk Speedway. Tire manufacture TBA. Tire usage rule maybe affect will be posted before start of season.**

One (1) mirror allowed maximum size 4". Must be on left side of driver close to door ledge and may not extend outside body.

MANDATORY SCANNER RULE IN EFFECT: Scanners only: See general rules.

*** Indicates changes from 2021 rules.**

The rules and/or regulations set forth herein are designed to provide for the orderly conduct of racing events and to establish minimum acceptable requirements for such events. These rules shall govern the condition of all events, and by participating in these events all participants are deemed to have obtained, read, and understood a copy of the current rules, and complied with these rules. NO EXPRESS OR IMPLIED WARRANTY OF SAFETY SHALL RESULT FROM PUBLICATION OF OR COMPLIANCE WITH THESE RULES AND/OR REGULATIONS. They are intended as a guide for the conduct of the sport and are in no way a guarantee against injury or death to a participant, spectator, or official

SEEKONK SPORTS TRUCK METRIC CHASSIS DIAGRAM

MEASUREMENTS IN INCHES

